



JS 系列

蛇形弹簧联轴器

Series JS Steelflex Tapered Grid Coupling

符合JB/T 8869-2000 Comply to JB/T 8869-2000

2020年7月版 Jul.2020 Edition



JS系列蛇形弹簧联轴器用于集装箱起重机大车行走
JS couplings are working on gantry walking

宁波伟隆港口机械有限公司

NINGBO WEILONG PORT MACHINERY CO., LTD.

宁波伟隆传动机械有限公司

NINGBO WEILONG TRANSMISSION MACHINERY CO., LTD.

品种齐全的蛇型弹簧联轴器供您选择！

Complete variety steelflex coupling give you more option!



JS100系列
Series JS100

基本型
Basic Coupling with
Horizontal Split Cover



JS500系列
Series JS500

远传式
Double Piloted Coupling
with Floating Shaft



JS200系列
Series JS200

中、高速型
Medium & High Speed



JS600系列
Series JS600

带制动轮式
Coupling with Brake Wheel

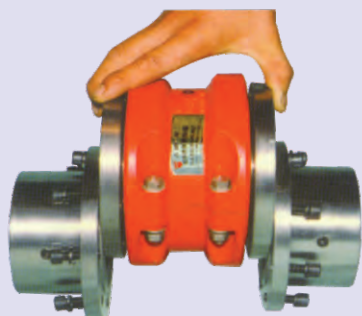

JS300系列
Series JS300

全卸式
Full Spacer Coupling

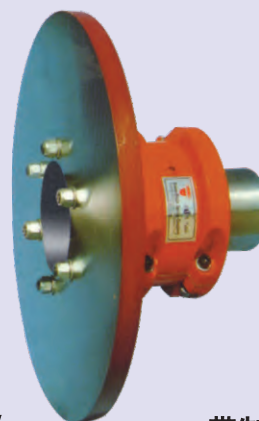

JS6300系列
Series JS6300

带制动盘式
Coupling with Brake Disc



JS3500系列
Series JS3500

半卸式
Half Spacer Coupling



JS700系列
Series JS700

高速型
High Speed Coupling

一. JS 型蛇形弹簧联轴器特点

1. Features of Series JS Tapered Steelflex Grid Coupling

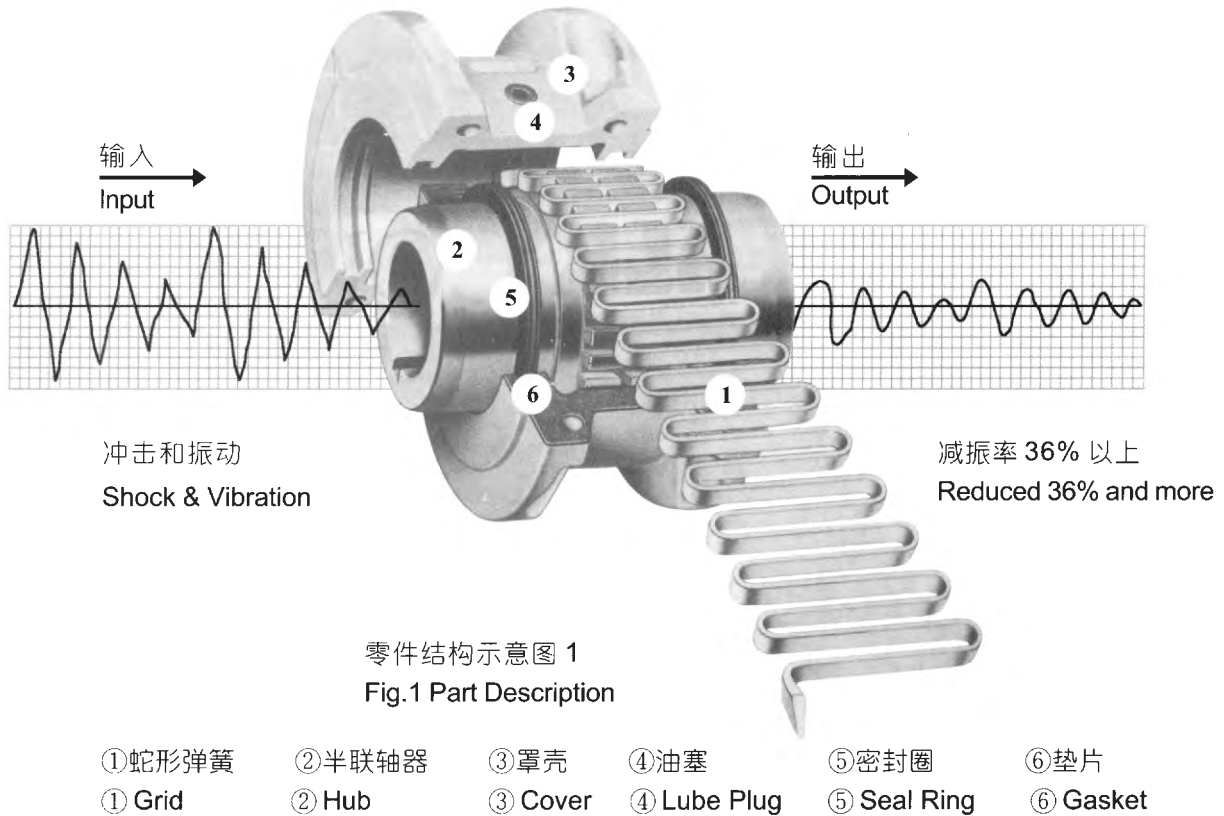

JS 型蛇形弹簧联轴器，是一种结构先进的金属弹性联轴器。它靠蛇形弹簧片来传递扭矩。其传动特性与优点如下：

1、减振性好，使用寿命长

联轴器以蛇形弹簧片轴向嵌入两半联轴器的齿槽内来实现原动机与工作机的联接，运转时，靠原动端齿面对簧片的周向作用力带动从动端来传递扭矩。如此在很大程度上避免了原动机与工作机的共振现象发生，且簧片在传递扭矩时所产生的弹性变形，使机械系统能获得较好的减振效果，其平均减振率经测定达36%以上。

梯形截面的蛇形弹簧片采用优质弹簧钢，经严格的热处理，并特殊加工而成，具有良好的机械性能，从而使联轴器的使用寿命远比非金属弹性元件联轴器（如弹性套柱销、尼龙棒销联轴器）大为增长。

2、承受变动载荷范围大，起动安全

两个半联轴器与簧片接触的齿面是弧形的，

Series JS Steelflex Tapered Grid Coupling is a kind of steelflex coupling with advanced structure, whose torque is transmitted by the grid. Following is the function and advantages of the coupling:

1. Good vibration-dampening capability and long service life

This coupling can join driven machine to prime mover by axially inserting grid into the tooth grooves of two hubs. When machine work, The torque, which created from the driving teeth apply the tangential force to grid. can be transmitted to drive the driven parts. So the resonance of driving mechanism and driven mechanism can be avoided effectively. And the elastic deformation of the grids during course of the torque transmitted, that can improve vibration dampening ability of the system. Statistical data stating, the average ratio of vibration dampening can reach to 36% or more.

A trapezoidal section grid is made of high strength spring steel, it is heat-treated strictly and treated through special process, it has excellent mechanical properties. So the service life of this coupling is much longer than that of non-metallicflex couplings.

当传递扭矩增大时，弹簧片将沿齿弧面变形，使两个半联轴器作用在簧片上的力点靠近（详见示图）。簧片与齿面的接触点即力矩的变化，是随着传递扭矩的大小而变化，它的传动特性是变刚度的，因而它具有比一般弹性联轴器能承受更大的载荷变动量。

从下图可见，传动力使簧片沿齿弧变形时所产生的缓冲作用，尤其在机器起动时或强力冲击载荷时，于一定程度上有保护配套机件的安全性。

3、传动效率高，运行可靠

联轴器的传动效率，经测定达 99.47%，其短时超载能力为额定扭矩的两倍，运行安全可靠。

4、噪声低，润滑好

铝合金罩壳以保护弹簧避免运转时向外甩出，且壳体内储满黄油，不仅使润滑良好，而且使簧片啮合时的噪声被黄油阻尼吸收而消除。

5、结构简单，装拆方便

整机零件少，体积小，重量轻，被设计成梯形截面的弹簧片与梯形齿槽的吻合尤为方便、紧密，从而使装拆、维护比一般联轴器简便。

6、允许有较大的安装偏差

由于弹簧片与齿弧面是点接触的，所以使联轴器能获得较大的挠性。它能被安装在同时有径向、角向、轴向的偏差情况下正常工作，具体安装偏差值见表 9。

2. A wide range of load, starting safely

The contact surface between two hubs and grid is arched shape. When the torque is increasing, The grid will be deformation along the arched tooth face, that make the distance of force point which applied on the grid by two hubs closed (for details see fig. 2). The change amount of contact point and the variation of torque depend on the variation of transformation torque. The transformation properties are varying stiffness. So this coupling can bear larger load variation than common steelflex coupling.

See from fig2, especially when the compliance started and shock loaded, the performance of damping from the transmission strength force the grids deformed, which can protect all kits, that make work safer.

3. High efficiency of transmission, High reliability services.

Through testing, the transmission efficiency is as much as 99.47%. Short overload capacity is more than 200% rated torque. The machine runs safely and reliably.

4. Lower noise and good lubricity

Aluminum-alloy cover can avoid the grid be thrown out during operated. Grease filled into the cover assures good lubricity and eliminates the noise.

5. Simple construction, Easy assembly and disassemble.

The Complete set made up of only a few components, with small size and lightweight. It's extra convenient of meshing of trapezoid section grids and trapezoidal grooves, that makes it easier than common coupling on assembly, disassemble and maintenance.

6. Large allowable deviation of assembly

As the contact between grid and arched tooth is coincident automatically, the coupling can work normally with radial, angular and axial assembly deviation. The details allowable assembling deviations see the table 9.

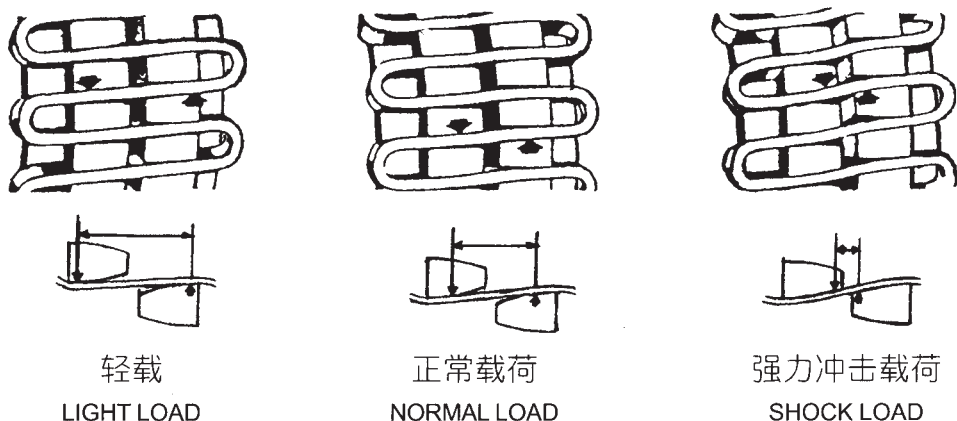

蛇形弹簧联轴器工作情况示意图 2

Fig.2 Illustration of Tapered Grid Steelflex Coupling Under Different Load

二. JS 型蛇形弹簧联轴器的标记方法

订购联轴器时, 请按GB/T3852-1997规定的标记方法:

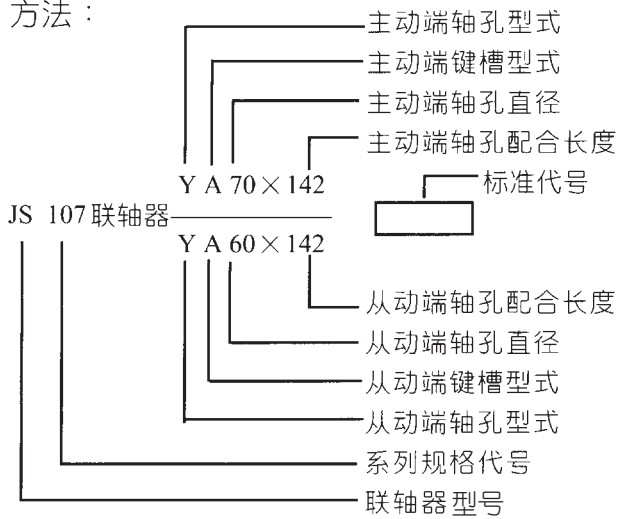

说明:

- (1) 本联轴器的标准代号为JB/T8869-2000 (标记式中可以省略不写)
- (2) 各种非标轴孔、键槽、轴孔配合长度, 只要在标记中写明, 本厂均承接制造。

标记示例 1: JS105 联轴器

主动端: Y 型轴孔、A 型键槽、 $d_1=48\text{mm}$
 $L=62\text{mm}$

从动端: Z 型轴孔、C 型键槽、 $d_2=40\text{mm}$
 $L=62\text{mm}$

标记为: JS105 联轴器 $\frac{\text{YA48}}{\text{ZC40}}$

因其主、从动端配合长度符合表 1 中 L 的规定数值, 故在订购联轴器时标记可省略。

标记示例 2: JS107 联轴器

主动端: Y 型轴孔、A 型键槽、 $d_1=70\text{mm}$
 $L=142\text{mm}$

从动端: Y 型轴孔、A 型键槽、 $d_2=60\text{mm}$
 $L=142\text{mm}$

标记为: JS107 联轴器 $\frac{\text{YA70} \times 142}{\text{YA60} \times 142}$

因其主、从动端配合长度不符合表 1 中 L 的规定数值, 故在订购联轴器时必须标注配合长度值。

2. The identification mark of JS series tapered grid steel flex coupling

Refer to GB/T3852-1997 China nation standard)

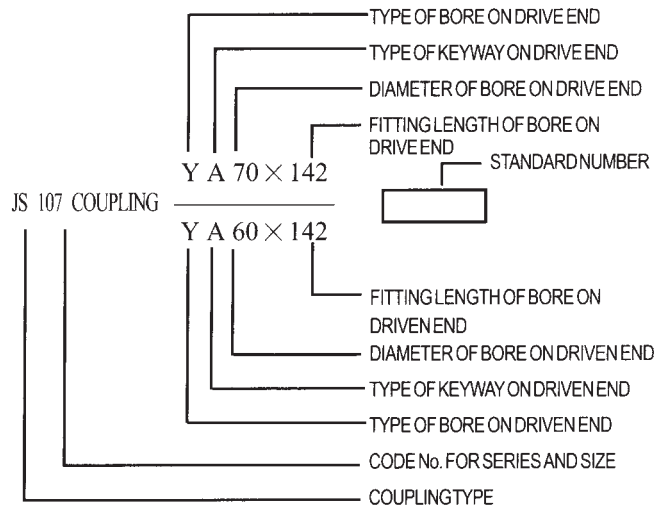

NOTES:

1. The standard code of JS series diaphragm coupling is JB/T8869-2000 (can be omitted in mark).
2. Various nonstandard bores, keyway and fitting length may be available as long as they have been indicated, we can design and manufacture the coupling upon your idea.

Example 1: JS105 coupling

Driving end: Type Y Bore, Type A keyway, $d_1=48\text{mm}$
 $L=62\text{mm}$

Driving end: Type Z Bore, Type C keyway, $d_2=40\text{mm}$
 $L=62\text{mm}$

Identification mark will be: JS105 coupling $\frac{\text{YA48}}{\text{ZC40}}$

Because the fitting length of the driving end and driven end comply with the values in table 1. The identification mark can be omitted in purchasing specification.

Example 2: JS107 Coupling

Driving end: Type Y Bore, Type A keyway, $d_1=70\text{mm}$
 $L=1142\text{mm}$

Driven end: Type Z Bore, Type C keyway, $d_2=60\text{mm}$
 $L=142\text{mm}$

Identification mark will be: JS107 Coupling $\frac{\text{YA70} \times 142}{\text{YA60} \times 142}$

Because the fitting length of driving end and driven end do not comply with the values in table 1, the fitting length must be noted clearly in purchasing specification.

三. JS 型蛇形弹簧联轴器的轴孔、键槽型式及配合代号

轴孔型式及其代号 Type and symbol of bore

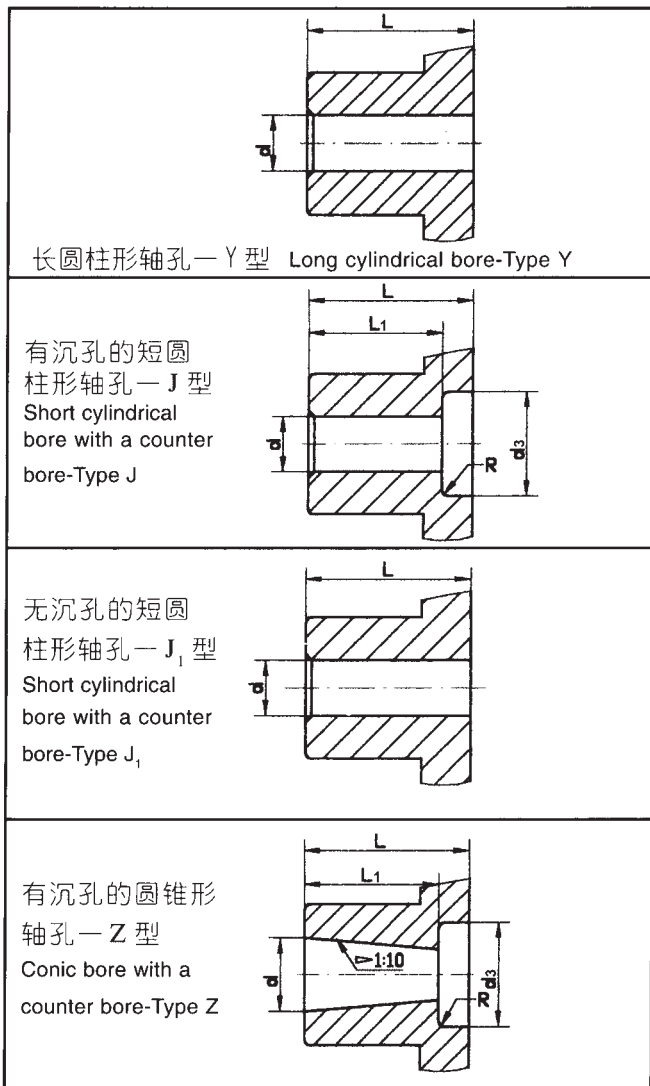

注：键槽宽度采用GB/T 1095-2003《平键、键和键槽的剖面尺寸》标准。键槽宽度的极限偏差同样采用上述标准中规定的JS9。

如用户的轴伸键槽不符合GB/T 1095-2003标准，请务必在订货时说明。

轴孔和轴伸的配合

直径 d	配合代号	
6-30	H7/J6	根据使用要求，也可选用 H7/r6 或 H7/N6 配合
>30-50	H7/K6	
>50	H7/m6	

注：(1) 选用过盈大于表中规定的配合时，应验算联轴器轮毂强度。

(2) 采用无键过盈联接的配合，按要求另行选定。

3. Fitting code and type code of bore, Keyway of JS Series tapered grid steelflex coupling

键槽型式及其代号 Type and symbol of keyway

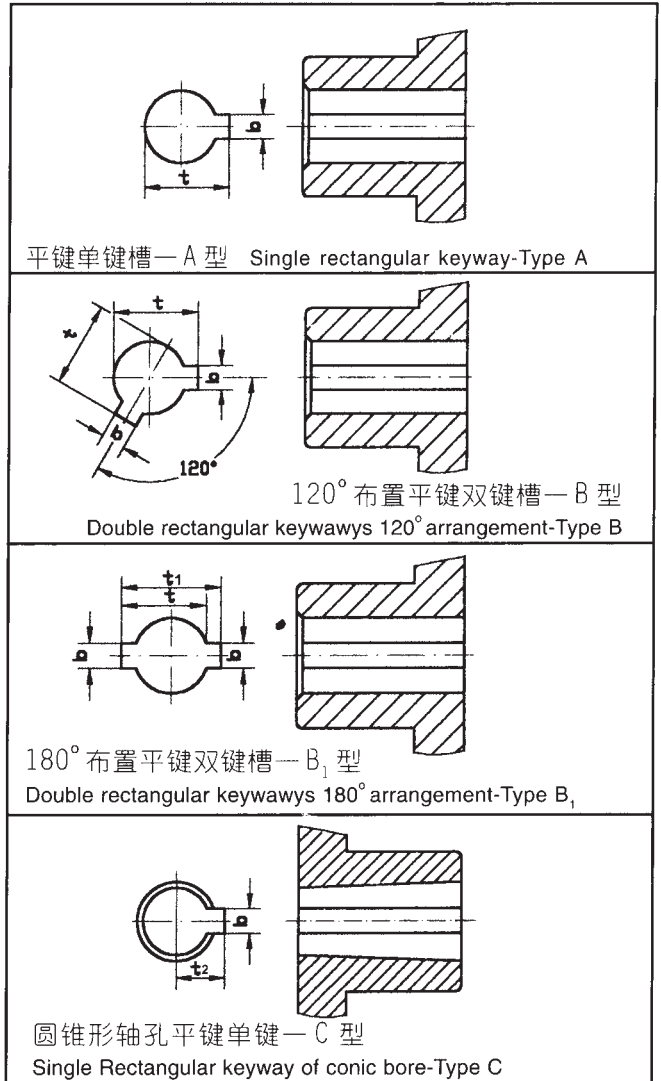

Note: The width of keyway refer to standard GB/T 1095-2003 《Sectional Dimension of straight key, key and keyway》, limited tolerance of the width of keyway also adopts JS 9 grade in the standard above stated. If the customer's shaft extension keyway is not compliance with the standard GB/T 1095-2003, please note it in purchasing list.

FITTING OF SHAFT EXTENSION AND BORE

Diameter d	Fit tolerance	
6-30	H7/J6	H7/r6 or H7/N6 may also be chosen depending on the application requirement.
>30-50	H7/K6	
>50	H7/m6	

Note: (1) If the selected interference fitting is beyond the range of values specified in table, the strength of the hub shall be checked.

(2) If interference fit without key connection is adopted, Re-select the fitting code according to other requirements.

四. JS型蛇形弹簧联轴器的选用方法

联轴器是根据负荷情况、计算扭矩、轴孔直径、工作转速来选择的。(选定联轴器的型号后应对轴和键的强度作校核验算)

计算扭矩 T_c 由下式求出：

$$T_c = K \cdot T = K \times 9550 \frac{P_w}{n} = K \times 7020 \frac{P_H}{n} \leq T_n (N \cdot m)$$

式中： T —理论扭矩 ($N \cdot m$) P_H —驱动功率 (HP)

T_n —公称扭矩 ($N \cdot m$) n —工作转速 (r/min)

T_c —计算扭矩 ($N \cdot m$) K —工作情况系数

P_w —驱动功率 (KW)

当根据最大计算扭矩 T_c 选得的联轴器，其允许最大轴孔尺寸不能满足轴伸尺寸的要求时，应改选为能同时满足扭矩和轴伸尺寸的联轴器规格。

工作情况系数 K

原 动 机		工 作 机					
		I类	II类	III类	IV类	V类	VI类
电动机、汽轮机		2.3	2.7	3	3.4	4.1	5.6
内 燃 机	6缸及6缸以上	2.8	3.2	3.5	3.9	4.6	6.1
	4缸或5缸	3.3	3.7	4	4.4	5.1	6.6
	双缸	3.6	4	4.3	4.7	5.4	6.9
	单缸	4	4.4	4.7	5.1	5.8	7.3

工作机分类

I类：扭矩变化很小机械：离心泵、小型发电机、皮带输送机、通风机、液体搅拌机。

II类：扭矩变化小机械：透平压缩机、木工机床、运输机。

III类：扭矩变化中等机械：搅拌器、往复泵，有飞轮压缩机、冲床。

IV类：扭矩变化和冲击载荷中等的机械：织布机、水泥搅拌机、拖拉机、提升机。

V类：扭矩变化和冲击载荷大机械：造纸机械、挖掘机、起重机、破碎机，鼓风机。

VI类：扭矩变化大并有强烈冲击载荷的机械：压延机械、无飞轮的活塞泵、重型初轧机。

4. Size Selection

The choosing method of coupling is based on load state, calculating torque (T_c), bore diameter and working speed.

Following is formula for calculating torque T_c :

$$T_c = K \cdot T = K \times 9550 \frac{P_w}{n} = K \times 7020 \frac{P_H}{n} \leq T_n (N \cdot m)$$

Where: T —Theoretical Torque ($N \cdot m$)

T_n —Nominal Torque ($N \cdot m$)

T_c —Calculating Torque ($N \cdot m$)

P_w —Drive Power (KW)

P_H —Drive Power (HP)

n —Allowable Rating Speed (r/min)

K —Working Factor (Refer to Table 2)

If the choosing method of coupling is base on the calculating torque (T_c). Max shaft extension size of the chosen coupling can't match the shaft extension measure, to meet the both requirements of the torque and shaft extension size, the coupling should be re-chosen again.

Working factor: K

PRIME MOVER		WORKING MACHINE					
		Type I	Type II	Type III	Type IV	Type V	Type VI
Electric motor, Steam turbine		2.3	2.7	3	3.4	4.1	5.6
Internal combustion engine with Cylinders No.	6 OR MORE	2.8	3.2	3.5	3.9	4.6	6.1
	4 OR 5	3.3	3.7	4	4.4	5.1	6.6
	Double	3.6	4	4.3	4.7	5.4	6.9
	Single	4	4.4	4.7	5.1	5.8	7.3

Classification of working machine

Type I: Machines with micro varied torque, such as: Centrifugal pumps, small-size generator, belt conveyors, and ventilators and liquid stirrer.

Type II: Machines with slightly varied torque, such as: turbocompressor, timber lathe, conveyor.

Type III: Machines with medium varied torque, such as: Stirrer, Reciprocating pump, compressor with flywheel, punch.

Type IV: Machines with highly varied torque and medium shocked load, such as: loom, cement stirrer, tractor, crane.

Type V: Machines with more highly varied torque and larger shocked load, such as: paper machine, excavator, crane, crusher, fan.

Type VI: Machines with large variable torque and strong shock load, such as: Press & extension machinery, plunger pump without flywheel heavy blooming mill.

五. JS100 系列蛇形弹簧联轴器基本参数和主要尺寸(基本型)

5. Essential Parameters and overall Dimension of Series JS100 (Basic Type)

JS101~JS113 结构图

Construction dwg. of JS101~JS113

JS114~JS125 结构图

Construction dwg. of JS114~JS119



表 1

TABLE 1 (mm)

型号 Size	公称扭矩 Nominal tq. Nm	许用 转速 Allow. speed r/min	Y、Z轴孔 d_1 、 d_2 Y、Z Bore d_1 、 d_2		D	B	C	A	L	F	d_3	H	R	E	间隙K Gap K			充油脂量 Qty. of oil lub. Kg	转动 惯量 Inertia Kgm ²	无轴孔 重量 Net. Wt. Kg
			最大 Max.	最小 Min.											最小 Min.	标准 Nor.	最大 Max.			
JS101	45	4500	28	14	98	107	70	40	52	40	36	15	3	80	1.5	3	5	0.03	0.0056	2
JS102	125	4500	35	14	110	107	70	50	52	40	46	16	3	90	1.5	3	5	0.03	0.0089	2.8
JS103	224	4500	42	14	120	107	74	55	52	41	54	16	3	100	1.5	3	5	0.06	0.0133	3.6
JS104	400	4500	48	14	138	127	80	65	62	45	65	20	6	114	1.5	3	5	0.06	0.0291	6.5
JS105	630	4300	55	19	155	127	95	75	62	52	73	20	6	130	1.5	3	5	0.09	0.048	7
JS106	900	3900	65	19	170	167	98	90	82	55	85	22	6	146	1.5	3	5	0.09	0.075	12
JS107	1800	3500	75	28	195	228	120	105	112	66	103	32	9	168	1.5	4	6.5	0.17	0.199	20
JS108	3150	3500	85	28	212	228	124	125	112	70	117	35	9	186	1.5	4	6.5	0.26	0.341	27
JS109	5600	2450	100	42	248	290	160	140	142	-	136	43	12	214	1.5	6	10	0.43	0.816	50
JS110	8000	2300	110	42	274	290	166	160	142	-	152	44	12	236	1.5	6	10	0.51	1.2	59
JS111	12500	2000	125	60	324	290	190	180	142	-	165	51	15	260	1.5	6	13	0.74	2.39	77
JS112	18000	1800	150	70	368	350	190	220	172	-	208	52	16	304	1.5	6	13	0.91	4.49	126
JS113	25000	1600	180	70	400	350	200	255	172	-	235	57	19	336	1.5	6	13	1.14	8.10	170
JS114	35500	1500	200	110	458	430	275	270	212	-	267	63	19	395	3	6	13	1.9	13.3	253
JS115	50000	1300	220	120	500	430	275	305	212	-	305	70	19	435	3	6	13	2.8	22.33	358
JS116	63000	1200	250	130	565	510	310	360	252	-	347	76	19	488	3	6	13	3.5	39.63	501
JS117	90000	1100	275	150	610	510	310	395	252	-	-	-	-	530	3	6	13	3.8	69.2	640
JS118	125000	1000	305	150	675	610	325	440	302	-	-	-	-	605	3	6	13	4.4	102	870
JS119	180000	900	330	170	755	610	350	500	302	-	-	-	-	660	3	6	13	5.2	174	1116
JS120	224000	800	350	170	845	614	432	535	302	-	-	-	-	755	4	10	16	10.5	210	1420
JS121	315000	730	380	200	925	670	490	570	330	-	-	-	-	825	4	10	16	16.1	295	1800
JS122	400000	680	400	200	1010	670	546	610	330	-	-	-	-	910	4	10	16	24.1	385	2250
JS123	500000	630	430	250	1090	773	650	650	380	-	-	-	-	-	5	13	20	33.8	570	3000
JS124	630000	580	470	250	1190	773	700	710	380	-	-	-	-	-	5	13	20	50.2	815	3800
JS125	800000	540	500	250	1270	913	762	760	450	-	-	-	-	-	5	13	20	67.2	1260	4800

注：用户有需要各种非标轴孔、键槽、轴孔配合长度的，请在订货时标明，本厂均承接制造。以下各型号均可非标供货。

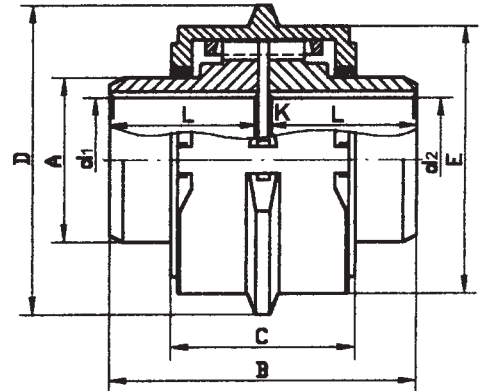
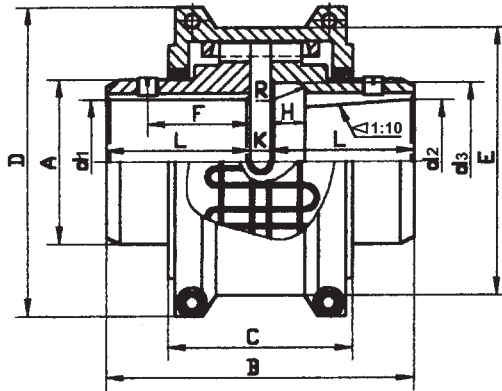
Notes: If custom requires the different size of bore, keyway and fitting length. We will be pleasure to supply. Please note clearly in purchasing list.

六. JS200 系列中. 高速蛇形弹簧联轴器基本参数和主要尺寸

6. Essential Parameters and Overall Dimension of Series JS200 Medium/High Speed Type

JS201~JS216 结构图

Construction dwg. of JS201~JS216

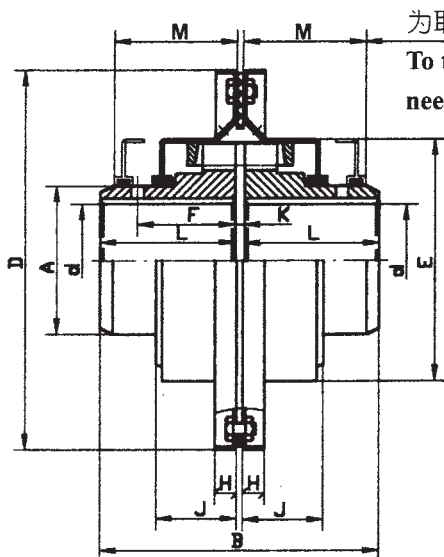

为取出弹簧、罩壳需移动的距离

To take out the grid, The distance of cover needs to be removed.

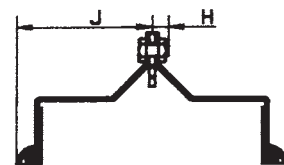

JS214~JS216 罩壳纵剖面
Section of cover for JS214~JS216

表 2

TABLE 2 (mm)

型号 Size	公称扭矩 Nominal tq. Nm	许用 转速 Allow. speed r/min	轴孔 d Bore d		D	B	J	A	L	F	E	H	M	间隙 K Gap K			充油脂量 Qty. of oil lub. Kg	无轴孔 重量 Net. Wt. Kg
			最大 Max.	最小 Min.										最小 Min.	标准 Nor.	最大 Max.		
JS201	45	6000	28	14	111	107	33	40	52	40	72	10	55	1.5	3	5	0.029	3
JS202	125	6000	35	14	120	107	33	50	52	40	82	10	55	1.5	3	5	0.029	3.4
JS203	224	6000	42	14	129	107	34	55	52	41	87	10	59	1.5	3	5	0.057	3.9
JS204	400	6000	48	14	148	127	39	65	62	45	100	12	68	1.5	3	5	0.057	6
JS205	630	5000	55	19	162	127	43	75	62	52	115	12.7	75	1.5	3	5	0.085	8
JS206	900	4500	65	19	173	167	45	90	82	55	134	12.7	78	1.5	3	5	0.085	12
JS207	1800	4200	75	28	200	228	60	105	112	66	153	12.7	105	1.5	4	6.5	0.17	19
JS208	3150	4000	85	28	232	228	60	125	112	70	170	12.7	108	1.5	4	6.5	0.255	26
JS209	5600	3200	100	42	267	290	72	140	142	--	200	15.7	134	1.5	6	10	0.425	39
JS210	8000	3000	110	42	286	290	74	160	142	--	218	15.7	135	1.5	6	10	0.51	54
JS211	12500	2700	125	60	319	290	89	180	142	--	250	17	157	1.5	6	13	0.74	72
JS212	18000	2400	150	70	378	350	89	220	172	--	294	21	159	1.5	6	13	0.91	117
JS213	25000	2200	180	70	416	350	89	255	172	--	327	21	165	1.5	6	13	1.14	169
JS214	35500	2000	200	110	476	430	106	270	212	--	388	24	202	3	6	13	1.9	242
JS215	50000	1700	220	120	533	430	114	305	212	--	424	30	216	3	6	13	2.8	349
JS216	63000	1600	250	130	584	510	119	360	252	--	474	30	226	3	6	13	3.5	491

注：(1) 半联轴器的轴孔 d 也可以做成锥形孔 (Z 型孔)，其锥孔尺寸与 JS100 系列的相同规格一样。

Notes: (1) The bore can be made into conic shape (called type Z), the dimension of conic bore is as same as the corresponding dimension specification of JS100.

七. JS300 系列全卸式蛇形弹簧联轴器基本参数和主要尺寸

7. Essential Parameters and Overall Dimension of Series JS300 Full Spacer Type

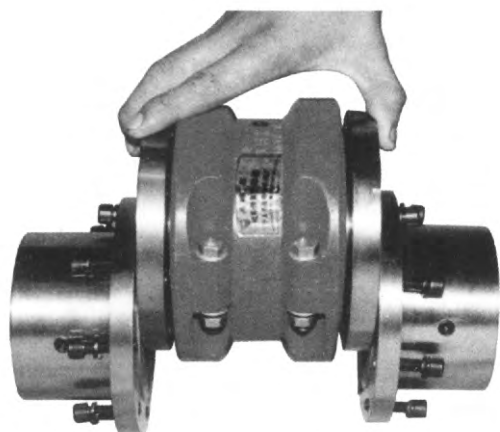

JS301~JS319 结构图

Construction dwg. of JS301~JS319



表 3

TABLE 3 (mm)

型号 Size	公称扭矩 Nominal tq. Nm	许用 转速 Allow. speed r/min	轴孔 d Bore d		D	BE		A	L	F	间隙 K Gap K 标准	充油脂量 Qty. of oil lub. Kg	无轴孔 重量 Net. Wt. Kg
			最大 Max.	最小 Min.		最小 Min.	最大 Max.						
JS301	45	3600	28	14	98	90	200	40	52	28	3	0.03	3.8
JS302	125	3600	35	14	110	90	220	50	52	32	3	0.03	5.2
JS303	224	3600	42	14	120	90	220	55	52	38	3	0.06	8.4
JS304	400	3600	48	14	138	110	220	65	62	40	3	0.06	12.4
JS305	630	3600	55	19	155	130	330	75	62	43	3	0.09	19.5
JS306	900	3600	65	19	170	130	330	90	82	47	3	0.09	24.4
JS307	1800	3500	75	28	195	190	410	105	112	50	4	0.17	39
JS308	3150	3500	85	28	212	190	410	125	112	57	4	0.26	60
JS309	5600	2450	100	42	248	210	410	140	142	--	6	0.43	98
JS310	8000	2300	110	42	274	210	410	160	142	--	6	0.51	136
JS311	12500	2000	125	60	324	250	410	180	142	--	6	0.74	195
JS312	18000	1800	150	70	368	260	410	220	172	--	6	0.91	257
JS313	25000	1600	180	70	400	270	410	255	172	--	6	1.14	338
JS314	35500	1500	200	110	458	350	380	270	212	--	6	1.9	447
JS315	50000	1350	220	120	500	360	410	305	212	--	6	2.8	547
JS316	63000	1220	250	130	565	390	450	360	252	--	6	3.5	829
JS317	90000	1100	275	150	610	400	500	395	252	--	6	3.7	1090
JS318	125000	1000	305	150	675	420	540	440	302	--	6	4.4	1466
JS319	180000	900	330	170	755	450	580	500	302	--	6	5.6	1840

订货须知：

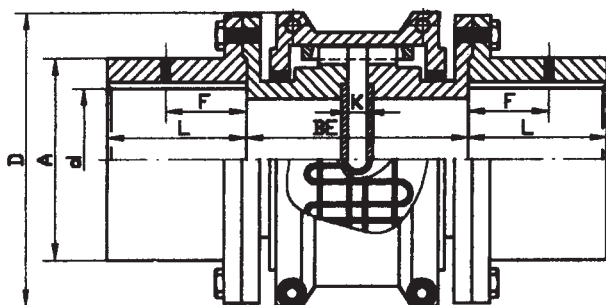
凡订购 JS300 型联轴器，除正确按 GB/T3852-1997 的标记方法标明型号、规格外，尚需说明两轴端间尺寸“BE”的长度，如订货时不说明，均按最小“BE”尺寸供货。

标记示例：JS310 联轴器 $\frac{YA100x127}{YA95x172}$ -BE250

Notes:

When ordering JS300, except the type and size must be noted according to GB/T3852-1997, the length of "BE" also be noted simultaneously. Otherwise, we will provide it upon the minium size of "BE".

Example: JS310 coupling $\frac{YA100x127}{YA95x172}$ -BE250

八. JS3500 系列半卸式蛇形弹联轴器基本参数和主要尺寸

8. Essential Parameters and overall Dimension of Series JS3500 Half Spacer Type

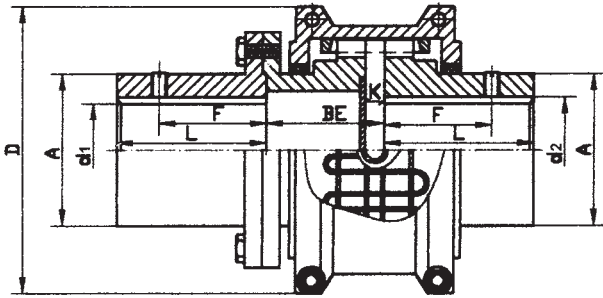

JS3501~JS3519 结构图

Construction dwg. of JS3501~JS3519

表 4

TABLE 4 (mm)

型号 Size	公称 扭矩 Nominal tq. Nm	许用 转速 Allow. speed r/min	轴孔 d_1 、 d_2 Bore d_1 、 d_2		D	BE		A	F	L	间隙 K Gap K 标准	充油脂量 Qty. of oil Lub. Kg	无轴孔 重量 Net. Wt. Kg
			最大 Max.	最小 Min.		最小 Min.	最大 Max.						
JS3501	45	3600	28	14	98	45	100	40	40	52	3	0.03	2.9
JS3502	125	3600	35	14	110	45	110	50	40	52	3	0.03	3.9
JS3503	224	3600	42	14	120	45	110	55	41	52	3	0.06	5.9
JS3504	400	3600	48	14	138	55	110	65	45	62	3	0.06	9
JS3505	630	3600	55	19	155	65	165	75	52	62	3	0.09	13.5
JS3506	900	3600	65	19	170	65	165	90	55	82	3	0.09	17.5
JS3507	1800	3500	75	28	195	95	205	105	66	112	4	0.17	28.5
JS3508	3150	3500	85	28	212	95	205	125	70	112	4	0.26	42.5
JS3509	5600	2450	100	42	248	105	205	140	-	142	6	0.43	70.5
JS3510	8000	2300	110	42	274	105	205	160	-	142	6	0.51	95
JS3511	12500	2000	125	60	324	125	205	180	-	142	6	0.74	138
JS3512	18000	1800	150	70	369	130	205	220	-	172	6	0.91	187
JS3513	25000	1600	180	70	400	135	205	255	-	172	6	1.14	257
JS3514	35500	1500	200	110	458	175	190	270	-	212	6	1.9	340
JS3515	50000	1300	220	120	500	180	205	305	-	212	6	2.8	430
JS3516	63000	1200	250	130	565	195	225	360	-	252	6	3.5	636
JS3517	90000	1100	275	-	610	200	250	395	-	252	6	3.7	852
JS3518	125000	1000	305	-	675	210	270	440	-	302	6	4.4	1118
JS3519	180000	900	330	-	755	225	290	500	-	302	6	5.6	1445

订货须知：

凡订购 JS3500 型联轴器，除正确按 GB/T3852-1997 的标记方法标明型号、规格外，尚需说明两轴端间尺寸“BE”的长度，如订货时不说明，均按最小“BE”尺寸供货。

标记示例：JS3510 联轴器 $\frac{YA100x127}{YA100x172}$ - BE 150

注： d_1 规定为标记示例中分子（主动端尺寸），用户有特殊要求请另行说明。

Notes :

When ordering JS3500, Except the type and size must be noted according to GB/T3852-1997, the length of "BE" also be noted simultaneously. Otherwise, we will provide it upon the minium size of "BE".

Example: JS3510 coupling $\frac{YA100x127}{YA100x172}$ - BE 150

Note: usually " d_1 " is regarded as the numerator in the mark (dimension of driving side). If the custom has a special requirement, please make description clearly.

九. JS500 系列远传式蛇形弹簧联轴器基本参数和主要尺寸

9. Essential Parameters and overall Dimension of Series JS500 Piloted Type



JS502~JS517 结构图

Construction dwg. of JS502~JS517



表5

TABLE5 (mm)

型号 Size	公称 扭矩 Nominal tq. Nm	许用 转速 Allow speed r/min	轴孔 d Bore d		A	BE 最小 Min.	D	E	N	L	M	P	J	SB	SD	最大 Max	间隙K GapK		(单个)* 无轴孔重量 Net. Wt. Kg
			最大 Max	最小 Min.													标准 Nor.	最小 Min.	
JS502	125	4500	35	14	50	160	126	80	90	52	78	20	55	32	38	5	3	1.5	4
JS503	224	4500	42	14	55	175	132	85	95	52	85	20	55	32	38	5	3	1.5	7
JS504	400	3900	48	14	65	195	155	105	105	62	95	20	60	32	38	5	3	1.5	9
JS505	630	3500	55	19	75	205	170	115	125	62	100	25	70	38	42	5	3	1.5	13
JS506	900	3500	65	19	90	210	195	125	140	82	105	25	80	45	50	5	3	1.5	16
JS507	1800	2450	75	28	105	275	218	140	155	112	135	25	85	60	65	6.5	4	1.5	26
JS508	3150	2300	85	28	125	295	240	160	175	112	145	30	95	70	75	6.5	4	1.5	37
JS509	5600	2000	100	42	140	370	270	180	205	142	180	30	115	90	95	10	6	1.5	63
JS510	8000	1800	110	42	160	390	290	200	230	142	190	35	125	100	105	10	6	1.5	83
JS511	12500	1600	125	60	180	450	325	220	258	142	220	35	150	115	120	13	6	1.5	97
JS512	18000	1500	150	72	220	465	365	265	300	172	225	45	155	130	135	13	6	1.5	139
JS513	25000	1300	180	70	255	480	400	295	335	172	235	50	165	140	145	13	6	3	208
JS514	35500	1200	200	110	270	550	460	320	390	212	270	50	190	160	165	13	6	3	275
JS515	50000	1100	220	120	305	590	506	350	430	212	290	65	210	200	205	13	6	3	378
JS516	63000	1000	250	130	360	620	550	400	475	252	305	70	220	200	205	13	6	3	315
JS517	90000	900	275	150	395	675	590	490	515	252	330	70	230	225	230	13	6	3	721

*:所谓“单个”是指左边一个或右边一个联轴器的重量。

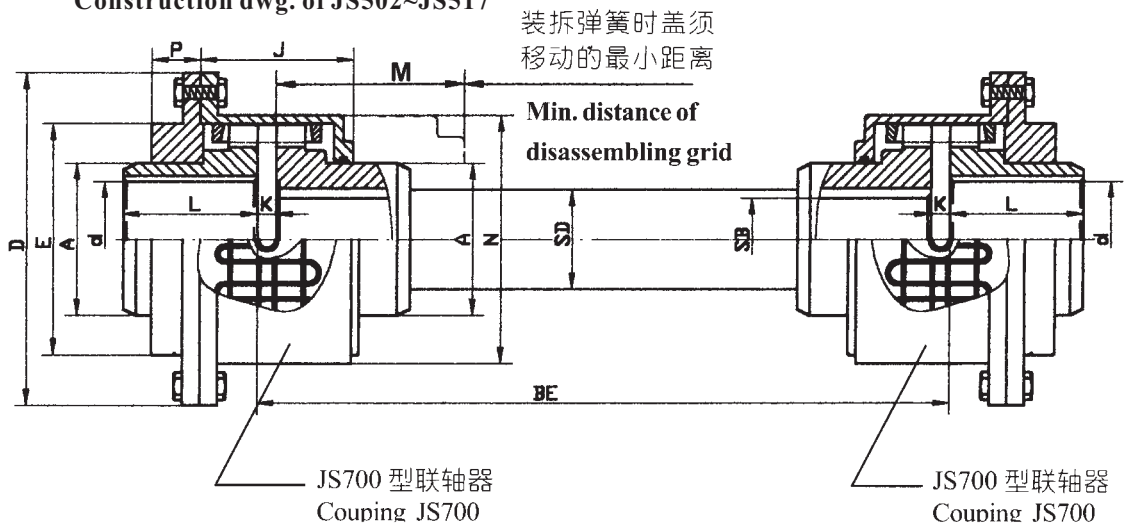
充油脂量参照JS100系列。

Notes:

The net weight means weight of left or right unit of coupling with lube.

十一. JS6200系列制动轮式蛇形弹簧联轴器基本参数和主要尺寸
 11. Essential Parameters And Overall Dimension Of Series Js6400 With Brake Wheel

JS6205~JS6215 结构图

Construction dwg. of JS26205~JS6215



表7

TABLE 7

制动轮 直径×宽度 E×F	型号	公称制动 扭矩 Nm	许用 转速 r/min	轴孔d		D	L	A	G	P	M	N	X	W		间隙K			充油 脂量 Kg
				最 大	最 小									单 向 制 动 轮	双 向 制 动 轮	最 大	标 准	最 小	
				205×90	JS6205									207	2870	55	19	155	
255×95	JS6206	328	2300	65	19	170	82	90	47	142	48	94.5	12	87	117	5	3	1.5	0.09
280×128	JS6207	630	2080	75	28	195	112	105	60	188	58	124	14	87	152	6.5	4	1.5	0.17
330×145	JS6208	1000	1770	85	28	212	112	125	14	159	109	86.5	14	87	152	6.5	4	1.5	0.26
405×170	JS6209	1800	1430	100	42	248	142	140	16	186	138	101	16	122	152	10	6	1.5	0.43
485×220	JS6210	2800	1200	110	42	274	142	160	-7	213	168	103	18	147	167	10	6	1.5	0.51
535×250	JS6211	4300	1100	125	60	324	142	180	-7	243	200	118	18	147	167	13	6	1.5	0.74
585×285	JS6212	6000	1000	150	70	368	172	220	-25	260	250	84.5	22	152	182	13	6	1.5	0.91
670×300	JS6213	8700	850	180	70	400	172	255	0	300	275	150	22	152	182	13	6	1.5	1.14
760×305	JS6214	12000	765	200	110	458	212	270	0	305	275	152.5	26	182	182	13	6	3	1.9
765×310	JS6215	16000	765	220	120	500	212	305	0	310	275	155	26	197	197	13	6	3	2.8

说明：联轴器的公称扭矩值与JS100系列相同。但制动盘的公称扭矩需按上表选择。

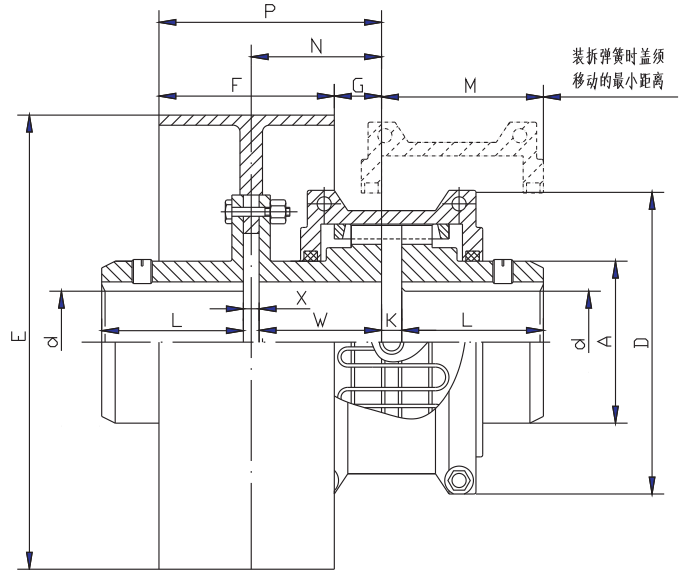
Notes: The nominal torque values of coupling is equal to JS100, but the nominal torque values of brake disc must be chosen from the table above listed.

十二、JS6300 系列制动盘式蛇形弹簧联轴器基本参数和主要尺寸

12. Essential Parameters and Overall Dimension of Series JS6300 with Brake Disc



表8

TABLE 8 (mm)

制动盘的直径 x 厚度 Disc Dia. x thick. E x F	型号 size	公称制动 扭矩 Nominal braking tq. Nm	许用 转速 Allow. speed r/min	轴孔 d Bore d		D	L	A	G	W 最小 Min.	C	X	间隙 K Gap K			无轴孔 重量 Net. Wt. Kg	充油脂量 Qty. of oil lub Kg
				最大 Max.	最小 Min.								最大 Max.	标准 Nor.	最小 Min.		
315 x 20	JS6305	207	3800	55	19	155	62	75	87	87	95	23	5	3	1.5	20	0.09
315 x 20	JS6306	328	3200	65	19	170	82	90	87	87	98	23	5	3	1.5	25	0.09
315 x 20	JS6307	630	2800	75	28	195	112	105	87	87	120	23	6.5	4	1.5	33	0.17
400 x 30	JS6308	1000	2700	85	28	212	112	125	87	87	124	33	6.5	4	1.5	57	0.26
400 x 30	JS6309	1800	2400	100	42	248	142	140	122	122	160	35	10	6	1.5	80	0.43
450 x 30	JS6310	2800	2200	110	42	274	142	160	147	147	166	38	10	6	1.5	97	0.51
500 x 30	JS6311	4300	2000	125	60	324	142	180	147	147	190	38	13	6	1.5	124	0.74
560 x 30	JS6312	6000	1800	150	70	368	172	220	152	152	190	38	13	6	1.5	184	0.91
630 x 30	JS6313	8700	1600	180	70	400	172	255	152	152	200	42	13	6	1.5	244	1.14
760 x 30	JS6314	12000	1500	200	110	458	212	270	182	182	275	42	13	6	3	360	1.9
915 x 30	JS6315	16000	1300	220	120	500	212	305	197	197	275	42	13	6	3	513	2.8

说明：联轴器的公称扭矩值与 JS100 系列相同，
但制动盘的公称扭矩值需按上表选择。

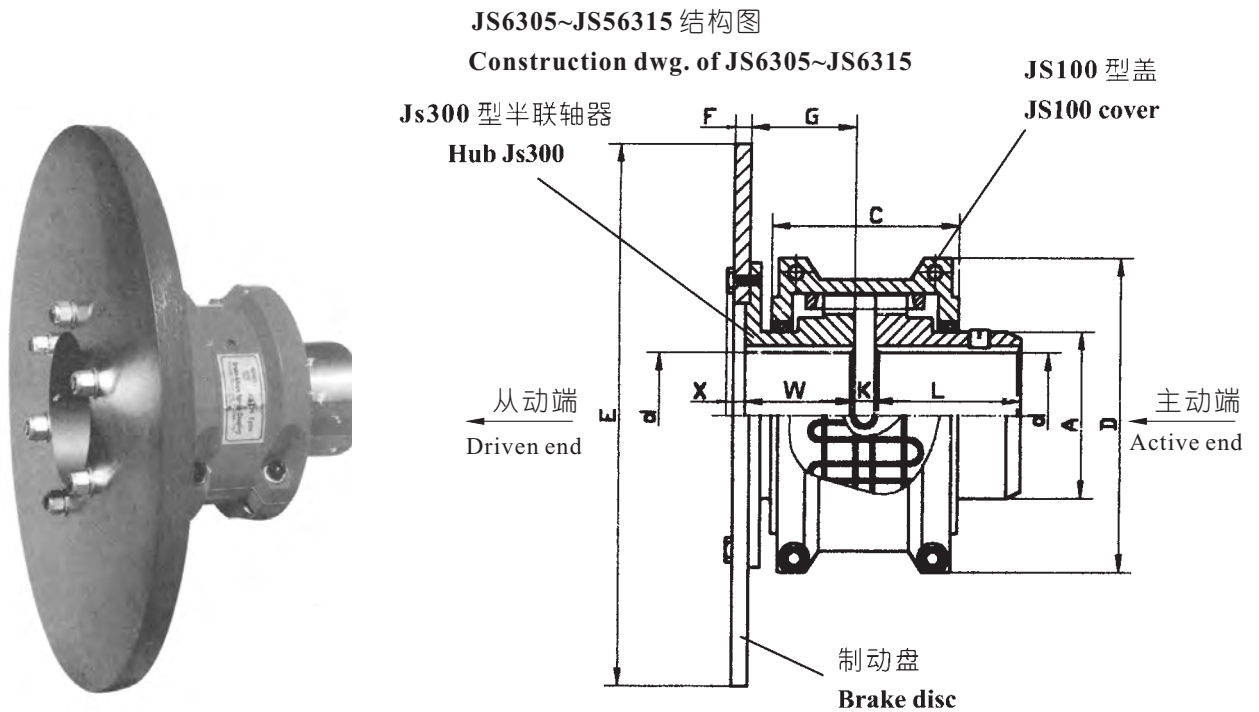
Notes: The nominal torque values of coupling is equal
to JS100, but the nominal torque values of
brake disc must be chosen from the table
above listed.

十三、JS6400系列制动盘式蛇形弹簧联轴器基本参数和主要尺寸

13. Essential Parameters And Overall Dimension Of Series Js6400 With Brake Disc

JS6405~JS56415 结构图

Construction dwg. of JS6405~JS6415



表9

TABLE9

制动轮 直径×宽度 E×F	型号	公称制动 扭矩 Nm	许用 转速 r/min	轴孔d		D	L	A	G	W 最小	C	间隙K			无轴孔 重量 Kg	充油 脂量 Kg	
				最 大	最 小							X 最 大	标 准	最 小			
315×20	JS6405	207	3800	55	19	155	62	75	87	87	95	14	5	3	1.5	20	0.09
315×20	JS6406	328	3200	65	19	170	82	90	87	87	98	14	5	3	1.5	25	0.09
315×20	JS6407	630	2800	75	28	195	112	105	87	87	120	14	6.5	4	1.5	33	0.17
400×30	JS6408	1000	2700	85	28	212	112	125	87	87	124	22	6.5	4	1.5	57	0.26
400×30	JS6409	1800	2400	100	42	248	142	140	122	122	160	22	10	6	1.5	80	0.43
450×30	JS6410	2800	2200	110	42	274	142	160	147	147	166	22	10	6	1.5	97	0.51
500×30	JS6411	4300	2000	125	60	324	142	180	147	147	190	22	13	6	1.5	124	0.74
560×30	JS6412	6000	1800	150	70	368	172	220	152	152	190	22	13	6	1.5	184	0.91
630×30	JS6413	8700	1600	180	70	400	172	255	152	152	200	22	13	6	1.5	244	1.14
760×30	JS6414	12000	1500	200	110	458	212	270	182	182	275	22	13	6	3	360	1.9
915×30	JS6415	16000	1300	220	120	500	212	305	197	197	275	22	13	6	3	513	2.8

说明：联轴器的公称扭矩值与JS100系列相同。但制动盘的公称扭矩需按上表选择。

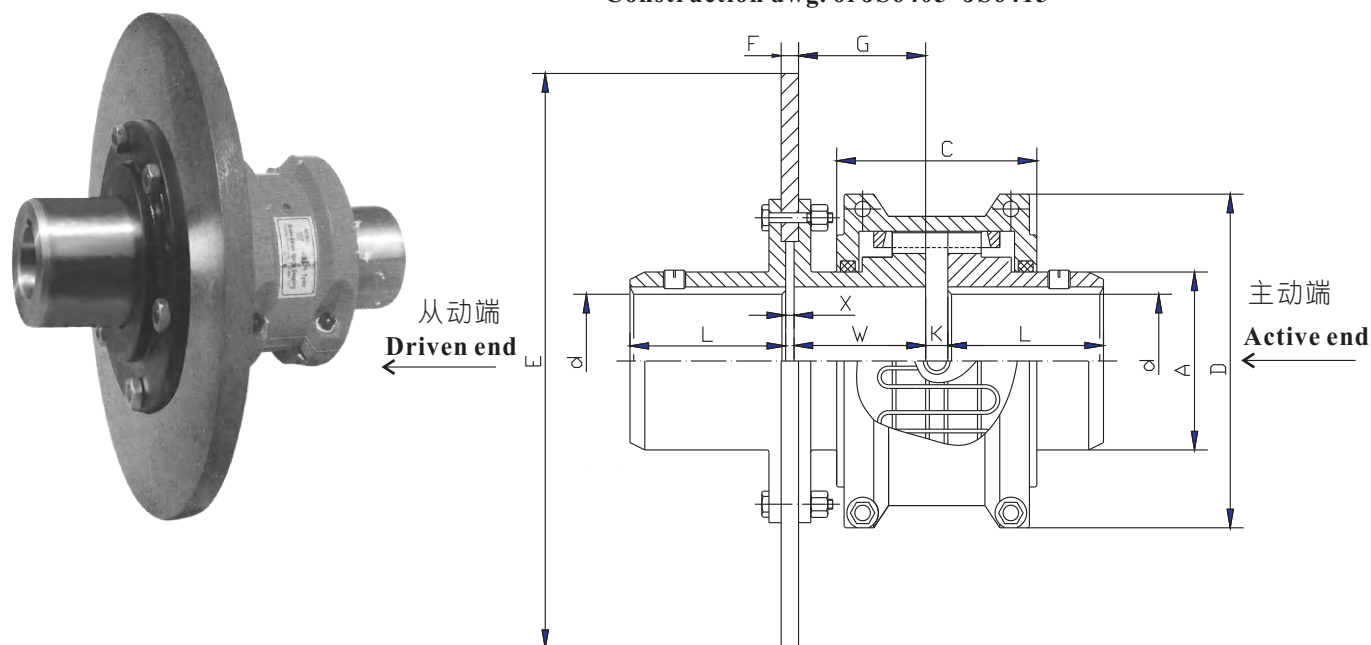
Notes: The nominal torque values of coupling is equal to JS100, but the nominal torque values of brake disc must be chosen from the table above listed.

十四、JS700 系列高速蛇形弹簧联轴器基本参数和主要尺寸

14. Essential Parameters and Overall Dimension of Series JS700 High Speed Type

JS 702~JS 717 结构图

Construction dwg. of JS702~JS717



表8

TABLE8 (mm)

型号 Size	公称 扭矩 Nominal tq. Nm	许用 转速 Allow speed r/min	轴孔 d Bore d		A	D	E	N	L	M	P	J	SB	SD	最大 Max	间隙K GapK 标准 Nor.	最小 Min.	(单个)* 无轴孔重量 Net. Wt. Kg
			最大 Max	最小 Min.														
JS702	125	10000	35	14	50	126	80	90	52	78	20	55	32	38	5	3	1.5	4
JS703	224	10000	42	14	55	132	85	95	52	85	20	55	32	38	5	3	1.5	7
JS704	400	9000	48	14	65	155	105	105	62	95	20	60	32	38	5	3	1.5	9
JS705	630	8500	55	19	75	170	115	125	62	100	25	70	38	42	5	3	1.5	13
JS706	900	8200	65	19	90	195	125	140	82	105	25	80	45	50	5	3	1.5	16
JS707	1800	7000	75	28	105	218	140	155	112	135	25	85	60	65	6.5	4	1.5	26
JS708	3150	6000	85	28	125	240	160	175	112	145	30	95	70	75	6.5	4	1.5	37
JS709	5600	4900	100	42	140	270	180	205	142	180	30	115	90	95	10	6	1.5	63
JS710	8000	4500	110	42	160	290	200	230	142	190	35	125	100	105	10	6	1.5	83
JS711	12500	4000	125	60	180	325	220	258	142	220	35	150	115	120	13	6	1.5	97
JS712	18000	3600	150	72	220	365	265	300	172	225	45	155	130	135	13	6	1.5	139
JS713	25000	3300	180	70	255	400	295	335	172	235	50	165	140	145	13	6	3	208
JS714	35500	3000	200	110	270	460	320	390	212	270	50	190	160	165	13	6	3	275
JS715	50000	2600	220	120	305	506	350	430	212	290	65	210	200	205	13	6	3	378
JS716	63000	2400	250	130	360	550	400	475	252	305	70	220	200	205	13	6	3	315
JS717	90000	2000	275	150	395	590	490	515	252	330	70	230	225	230	13	6	3	721

注：JS700 型高速蛇形弹簧联轴器的选用方法及标记方法均与 JS100 型相同。

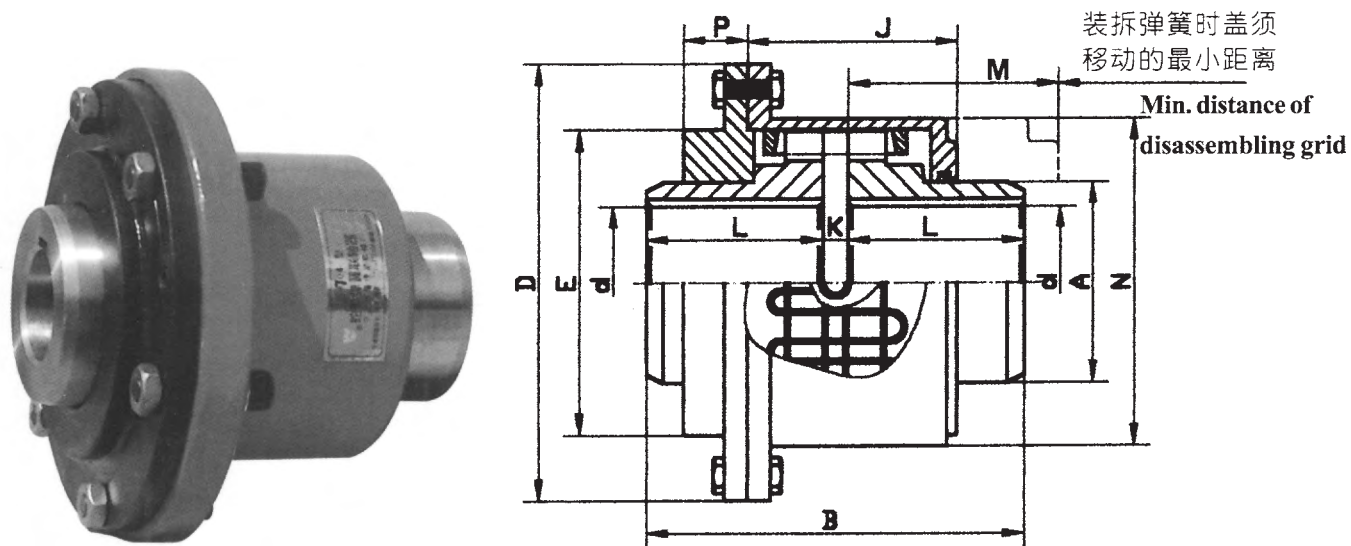
Notes: The choosing program and identification method is as same as JS100.

十五、JS系列蛇形弹簧联轴器许用补偿量

15. Permission compensation of series JS Steelflex Tapered Grid Coupling

表11

Table11(mm)

公称转矩 Rated Torque Tn N·m	最大允许安装误差 Max permissible mounting deviation				最大允许运转补偿量 Max permissible operating deviation			轴向△X Axial deviation Value	
	径向△Y Radial deviation value			角向△α △α=0.25°	径向△Y		角向△α △α=0.5°	其余型号 All type except JS300	JS300
	型式 Size				型式 Size				
	JS500	JS700	其余型号	A-A1	JS500 JS700	其余型号	A-A1		
45	—	—	0.15	0.076		0.31	0.25	±0.3	±0.5
140	0.05	0.076	0.15	0.076	0.15	0.31	0.31	±0.3	±0.5
224	—	—	0.15	0.076	—	0.31	0.33	±0.3	±0.5
400	0.05	0.1	0.2	0.1	0.2	0.41	0.4	±0.3	±0.5
630	—	—	0.2	0.127	0.2	0.41	0.45	±0.3	±0.5
900	0.05	0.1	0.2	0.127	0.2	0.41	0.5	±0.3	±0.5
1800	0.05	0.1	0.2	0.15	0.2	0.41	0.6	±0.3	±0.5
3150	0.076	0.1	0.2	0.18	0.2	0.41	0.7	±0.3	±0.5
5600	0.076	0.127	0.25	0.2	0.28	0.51	0.84	±0.5	±0.6
8000	0.076	0.127	0.25	0.23	0.28	0.51	0.9	±0.5	±0.6
12500	0.076	0.15	0.28	0.25	0.3	0.56	1	±0.6	±1
18000	0.1	0.15	0.28	0.3	0.3	0.56	1.2	±0.6	±1
25000	0.1	0.15	0.28	0.33	0.3	0.56	1.35	±0.6	±1
35500	0.1	0.15	0.3	0.4	0.38	0.61	1.57	±0.6	±1
50000	0.127	0.15	0.3	0.45	0.38	0.61	1.78	±0.6	±1
63000	0.127	0.15	0.3	0.5	0.38	0.61	2	±0.6	±1
90000	0.127	0.15	0.38	0.56	0.42	0.76	2.26	±0.6	±1
125000	0.15	0.2	0.38	0.6	0.42	0.76	2.46	±0.6	±1
160000	0.15	0.2	0.38	0.68	0.42	0.76	2.72	±0.6	±1
224000	—	—	0.46	0.74	—	0.92	2.99	±1.3	—
315000	—	—	0.46	0.8	—	0.92	3.28	±1.3	—
400000	—	—	0.48	0.89	—	0.97	3.6	±1.3	—
500000	—	—	0.48	0.96	—	0.97	3.9	±1.3	—
630000	—	—	0.5	1.07	—	1.02	4.29	±1.3	—
800000	—	—	0.5	1.77	—	1.02	4.56	±1.3	—

说明：最大运转补偿量是指在工作状态下，允许联轴器由安装误差、振动、冲击、温度变化等综合因素所形成的两轴相对的偏移量。

Note：Max permissible operating deviation is the max permissible displacement of two shafts of coupling, which is produced by installing, vibration, compact, and temperature.

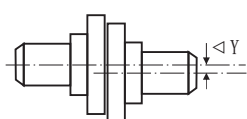

径向△Y
Radial direction

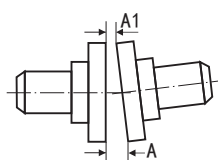

角向△α=0.5°
Angle direction

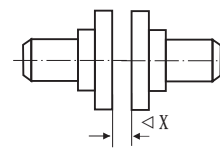

轴向△X
Axial direction

感谢您使用我公司生产的联轴器！

We appreciate you to choose our couplings!

我们有下列品种的联轴器可供您选择。

We are can supply below couplings for your option!



金属弹性元件，缓冲减振性好，使用寿命长。
Metal elastic component, good vibration-damping and long service life.

JS系列蛇形弹簧联轴器
Series JS steelflex grid coupling



弹性好，无润滑，高可靠。
Good flexibility, lubricant free and high reliable performance.

ML系列梅花形弹性联轴器
Series ML coupling with elastic spider



承载能力大，适用于低速重载工况。
Large loading capability, suit to use for low speed and heavy loading.

GICL, GIICL系列鼓形齿式联轴器
Series GICL & GIICL curved tooth coupling

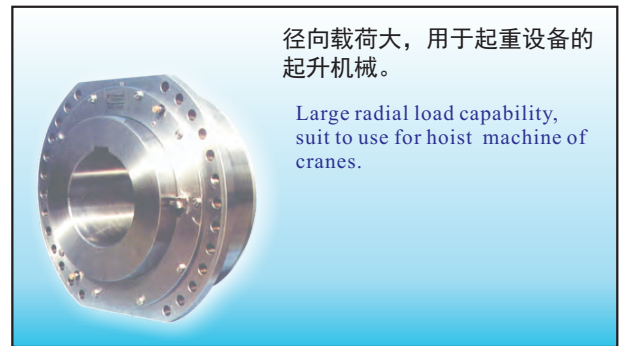

径向载荷大，用于起重设备的起重机械。
Large radial load capability, suit to use for hoist machine of cranes.

DC系列卷筒用鼓形齿式联轴器
Series DC curved tooth drum coupling

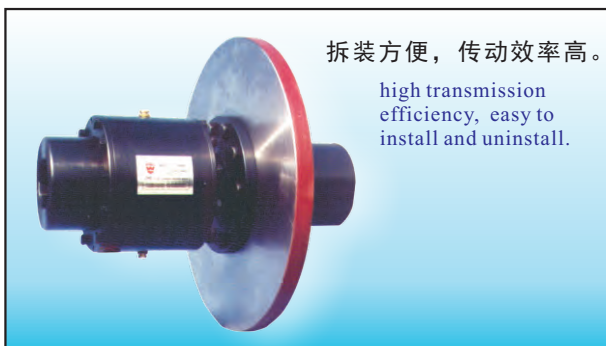

拆装方便，传动效率高。
high transmission efficiency, easy to install and uninstall.

PGCLK系列鼓形齿式联轴器
Series PGCLK curved tooth coupling



传动精度高，少维护，无噪声，寿命长。
high transmission accuracy, less maintenance, non-noise, and long service life.

JM系列膜片联轴器
Series JM diaphragm coupling

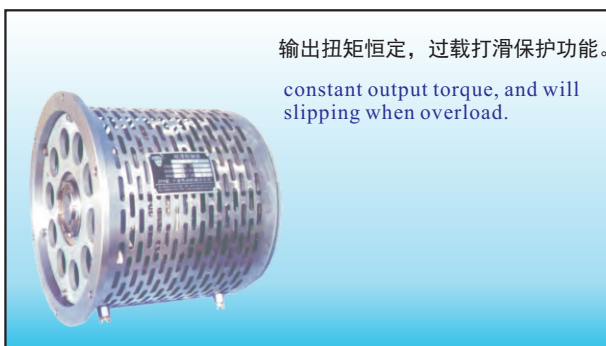

输出扭矩恒定，过载打滑保护功能。
constant output torque, and will slipping when overload.

MH系列磁滞联轴器
Series MH hysteresis coupling with permanent magnet



承载能力大，具有很大的角度补偿能力。
High capacity of loading, and large angular deviation compensation.

SWP、SWC系列十字轴式万向联轴器
Series SWP & SWC cardan universal coupling

新一代联轴器随主机远销国外！

Novel couplings companning with hoisting aooliances is sold overseas well!



宁波伟隆港口机械有限公司
NINGBO WEILONG PORT MACHINERY CO., LTD.
宁波伟隆传动机械有限公司
NINGBO WEILONG TRANSMISSION MACHINERY CO., LTD.

地址：中国宁波市梅湖创新工业园区
四香路1号

电话：(86)574-88372266 83066266

传真：(86)574-88372264 88373712

邮编：315121

公司网站：<http://www.weilongme.com.cn>

电子信箱：weilong@weilongme.com.cn

服务热线：(86)574-88373131 88395022

Addr: No.1, Si Xiang Lord, Meihu Innovation
Industrial Zone, Ningbo, China

Tel: (86)574-88372266 83066266

Fax: (86)574-88372264 88373712

P.C.: 315121

Web-site: <http://www.weilongme.com.cn>

E-mail: weilong@weilongme.com.cn

serve-online: (86)574-88373131 88395022